

# ULTIMATE

## *Endeavour*

The ULTIMATE *Endeavour* kit contains all the parts necessary\* to build a giant, flying high power rocket:

- 1) Pre-slotted main airframe
- 1) Payload section kit including:
  - 1) 36" Airframe section
  - 1) Coupler
  - 1) Bulk plate
  - 1) set of "U" bolt, nuts, & washers
- 1) Nose cone w/ coupling sleeve
- 3) Lower fins
- 3) Upper fins
- 1) Piston ejection kit including:
  - 1) Piston body
  - 1) Piston strap
  - 1) Slotted bulk plate
  - 1) Metal "Kwik-Link"
- 1) 62" Parachute
- 1) 44" Parachute
- 1) Main motor mount tube (54mm)
- 3) Outboard motor mount tubes (38mm)
- 2) Cluster mount centering rings
  - 1) Single hole, notched centering ring
  - 1) 1.5" x 144" Elastic shock cord
  - 1) 1.5" x 72" Elastic shock cord
- 2) 3/4" launch lugs
- 1) Instruction sheet (this one!)

\*Epoxy, paint, and motors not included.

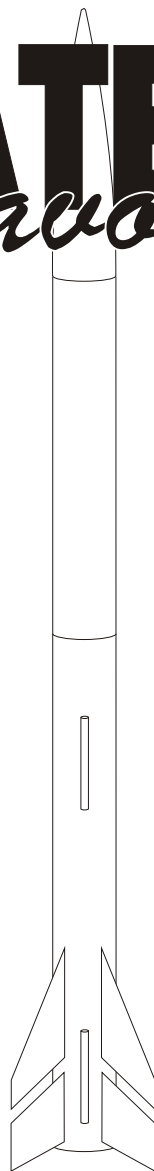

Public Missiles Ltd.

The center of pressure (CP) of this rocket is 84 inches from nose tip. After finishing your rocket, permanently mark the center of pressure on the airframe. Calculations made using RockSim 4.0 program for subsonic flights. After loading the rocket with a motor, make sure that the center of gravity (balancing point) is 6" forward of the center of pressure mark. The center of gravity can be moved forward by adding weight to the nose cone. It is impossible to test every rocket with every motor configuration therefore, if you are unsure about motor selection for any rocket consult the motor manufacturer.

# ULTIMATE Endeavour

## Assembly instructions

Please read and understand all instructions before continuing!

### Stuff you will need:

One set of each 5 and 15 minute epoxy  
 One sheet of each fine and medium sand paper  
 Ruler and pencil  
 12" x 12" piece of wax paper  
 Masking tape

NOTE: Be sure to scuff all parts to be bonded using medium sand paper.

### Step 1

**A)** Tape a 12" x 12" square of wax paper onto your work surface. Place one of the cluster centering rings in the middle of the wax paper sheet. **B)** Apply a heavy bead of epoxy to the end of the 24" long 54mm motor mount tube. **C)** Press the epoxied end of the tube into the center hole of the cluster centering ring. **D)** While gently applying downward pressure on the tube and using your other hand to keep the centering ring still, rotate the motor tube in one direction to help spread the epoxy. 6 to 8 complete rotations should be enough to spread the epoxy evenly and form a nice fillet. Make sure that excess epoxy did not flow into the adjacent holes. Double check that the tube is pressed firmly into the ring and in full contact with the work surface.. Allow the epoxy to cure.

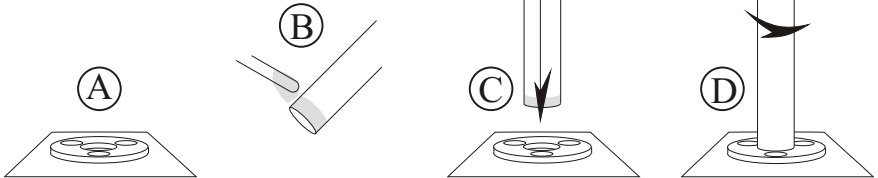

### Step 2

Using a pencil, make a mark around the circumference of all three 38mm motor mount tubes exactly 9" from one end. The end of the tube closest to the mark will be the "top".



Now repeat the same process as in step 1 with the three outboard motor mount tubes (applying the epoxy to the "bottom" end of the tubes). Use a slow setting epoxy so that you can install all three tubes at once. **A)** Once you have all three outboard tubes pressed into the centering ring, slip the other cluster ring over the top of the motor tubes to hold them in position while the epoxy cures. **B)** Move the upper cluster ring down to the marks on the outboard tubes and apply an epoxy fillet around every tube on both sides of the ring.

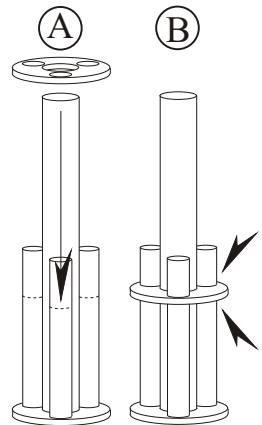

### Step 3

Apply a bead of epoxy to the top of the central motor mount and slip the single hole centering ring over the tube. The ring should be positioned 1/2" below the end of the tube. Be sure the notch in the centering ring is not obstructed by epoxy. Apply an epoxy fillet to both sides of the ring.

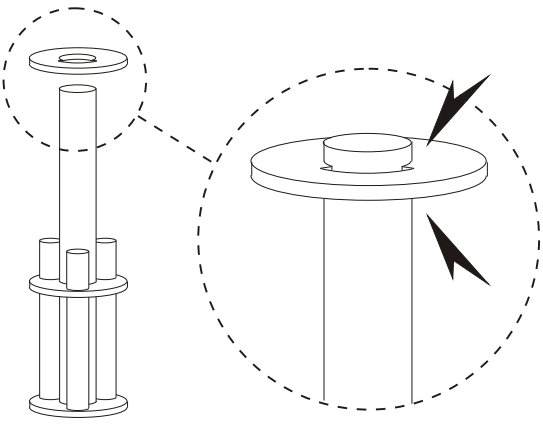

### Step 4

Epoxy one end (approx. 5-6") of the 2" wide piston strap to the outside of the motor mount tube. Use masking tape to hold the strap in place while the epoxy cures. Do not cut the strap. When the epoxy has cured, stuff the free end of the strap into the motor tube to keep it out of the way for the next few steps. Fill any gaps in the notch with epoxy.

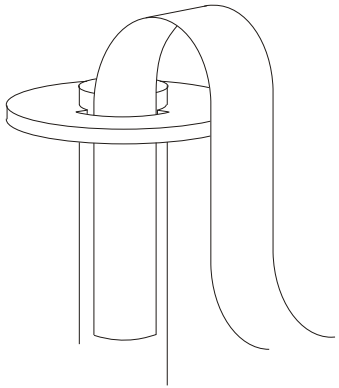

### Step 5

Slide the entire motor mount assembly into the aft end of the main airframe until about 7" of the assembly is left protruding.

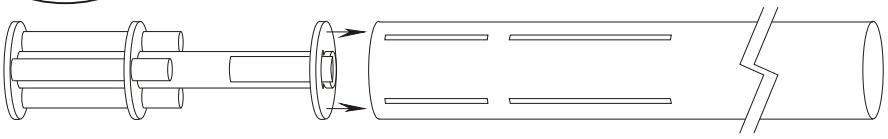

Carefully spread a heavy bead of epoxy inside the aft end of the airframe. Quickly slide the motor mount assembly into the airframe. Push it in until the aft end of the assembly is 1/4" deep in the airframe. Align the airframe so that the slots are precisely aligned between the outboard motor mount tubes as indicated below. Immediately stand the entire airframe/motor mount assembly upright until cured.

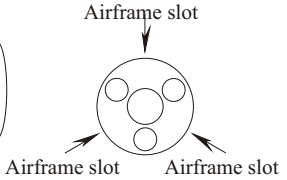
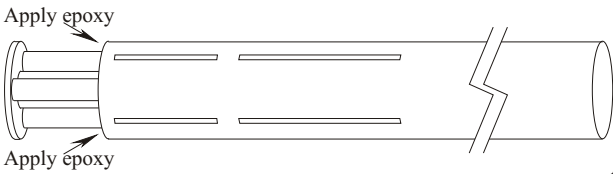

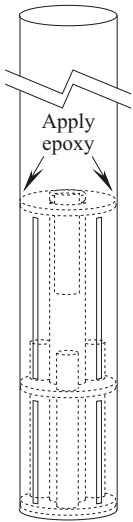

**Step 6**

Prepare a one ounce batch of epoxy in a small cup. With the airframe standing upright, reach into the tube and pour the epoxy onto the upper centering ring. Do not allow any epoxy into the motor mount tube. Tip the airframe at about a 45 degree angle and rotate it slowly. This will allow the epoxy to spread evenly around the perimeter of the centering ring. Allow the epoxy to cure.

Turn the airframe over and apply a fillet to the bottom centering ring. Allow the epoxy to cure.

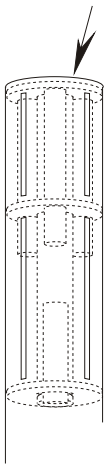
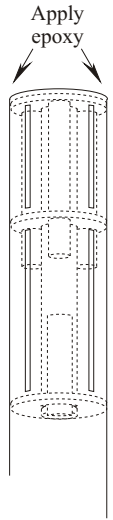

**Step 7**

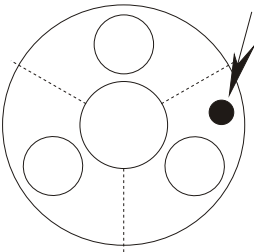

With the airframe still inverted, drill a 1/2" hole in the lower centering ring as shown. Mix a 2 oz. batch of slow setting epoxy. Carefully pour all of the epoxy into the hole. Tip the airframe assembly to about 45 degrees, wait a few seconds, then slowly rotate the airframe to spread the epoxy around the perimeter of the middle centering ring. After a few rotations, stand the airframe back up and allow the epoxy to cure.

The 1/2" hole can be left open or you can fill it with a wooden plug or bondo.

*NOTE: Similar holes can be drilled in this centering ring closer to the fin attach points for creating internal fin fillets in the next few steps.*

**Step 8**

1) Apply a bead of epoxy to the root edge of a fin. Push the fin through the slot in the airframe and against the central motor mount tube. Make sure that the fin is perpendicular to the airframe. Use tape to hold the fin in position while the epoxy cures. Repeat this process for all fins.

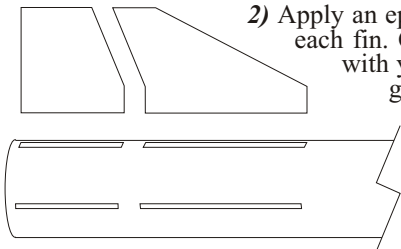

2) Apply an epoxy fillet to both sides of each fin. Carefully smooth the epoxy with your finger before it begins to gel. Allow the epoxy to set-up before rotating the rocket to do the next set of fins. Once the epoxy has fully cured, you should sand the fillet smooth with 180 grit sandpaper. Sanding will help the primer hold better to the epoxy.

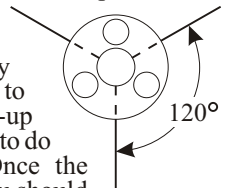

## Step 9

The strap referred to in this step is the strap you installed in the airframe in a previous step.

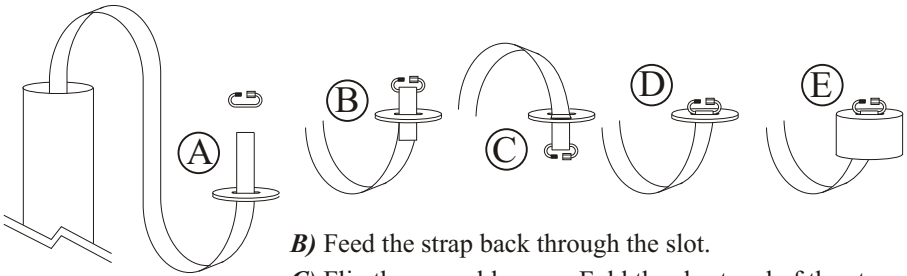

**A)** Pull the free end of the strap through the slot in the piston bulk plate. Slip the metal "Kwik-Link" over the strap.

**B)** Feed the strap back through the slot.

**C)** Flip the assembly over. Fold the short end of the strap flat against the bulk plate and epoxy in place.

**D)** When the epoxy has cured, pull the strap until the "Kwik-Link" is wedged at the slot. Apply epoxy to the strap at the "Kwik-Link".

**E)** Epoxy the bulk plate to the piston body 1/4" from the top. Apply an epoxy fillet to both sides of the bulkplate.

## Step 10

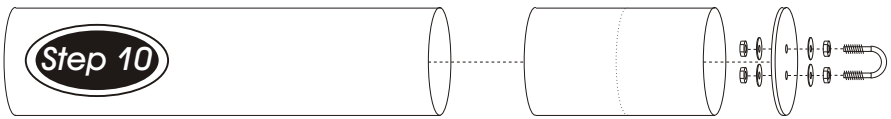

**1)** Screw a nut onto each leg of the "U" bolt. Place a washer over each leg of the "U" bolt. Fit the "U" bolt through the holes in the coupler bulkplate. Place another washer over each leg of the "U" bolt threads protruding through the bulkplate. Tighten the other nut against the washer of each leg of the "U" bolt. Epoxy the bulkplate assembly inside the coupler tube about 1/4" from the end. Apply an epoxy fillet to both sides of the bulkplate.

**2)** Draw a pencil mark around the coupler 6.0" from the end opposite the bulkplate. Spread some epoxy inside the payload section to a depth of about 4". Push the coupler into the payload section to the line.

## Step 11

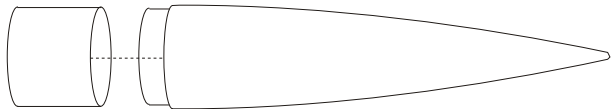

Epoxy the nosecone coupler over the nose cone shoulder.

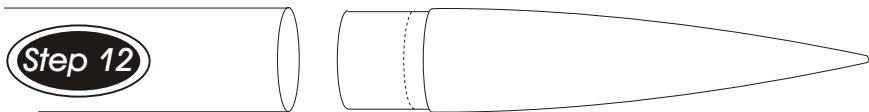

Drill a 3/16" hole in the payload section 12" from the top to bleed off air pressure build-up during flight. Install the nose cone atop the rocket and secure it in place using small pan head screws tapped into the shoulder of the nose cone (1/2" to 1" from the base of the nose cone). Pre-drill when using screws. Removable plastic rivets (RVT-24) can be used as well but must be drilled into the nose cone coupler. Just measure 2-3" from base of nose cone to locate holes.

### Step 13

Measure off the mid point of each parachute shroud line and mark it with a pen. Gather all the shroud lines making sure they are not twisted or tangled. Keep all the marks on the shroud lines together. Tie the lines together using a simple overhand knot leaving a small loop where all the marks meet. Tie the parachute to one end of the elastic shock cord. Tie the other end of the shock cord to the "Kwik-Link" on the piston.

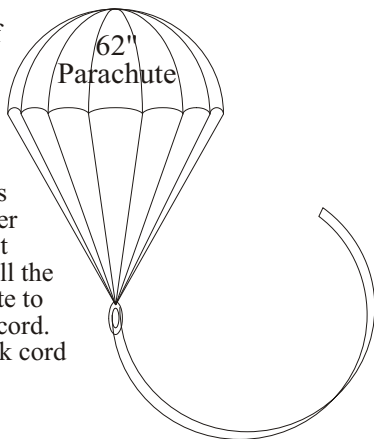

**NOTE:**  
When tying the shock cord to the parachute and the "Kwik-Link", loop the shock cord through twice then tie a double overhand knot. Pull the knot tight and leave a 2-3 inch trailer.

### Step 14

Measure off the mid point of each parachute shroud line and mark it with a pen. Gather all the shroud lines making sure they are not twisted or tangled. Keep all the marks on the shroud lines together. Tie the lines together using a simple overhand knot leaving a small loop where all the marks meet. Tie the parachute to one end of the elastic shock cord. Tie the other end of the shock cord to the eye bolt on the payload section.

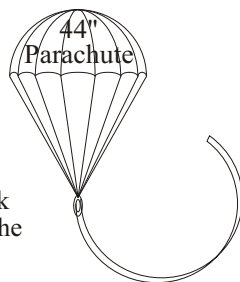

### Step 15

Slide the piston into the rocket followed by the shock cord and parachute. Place a sheet of paper towel over the parachute as a divider. Fold the payload section parachute and place it atop the paper towel inside the airframe. Place the payload section atop the rocket. Wrap masking tape around the coupler of the payload section if the fit is too loose. It should fit just tight enough to allow you to lift the rocket by the nose cone without it slipping off. Now install the motor and go fly

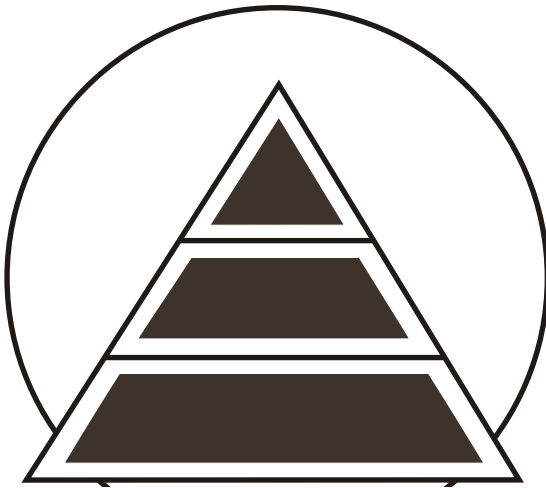

**Public Missiles Ltd.**

**ULTIMATE**  
*Endeavour*  
Assembly instructions